







GRINDING SOLUTIONS

磨削方案

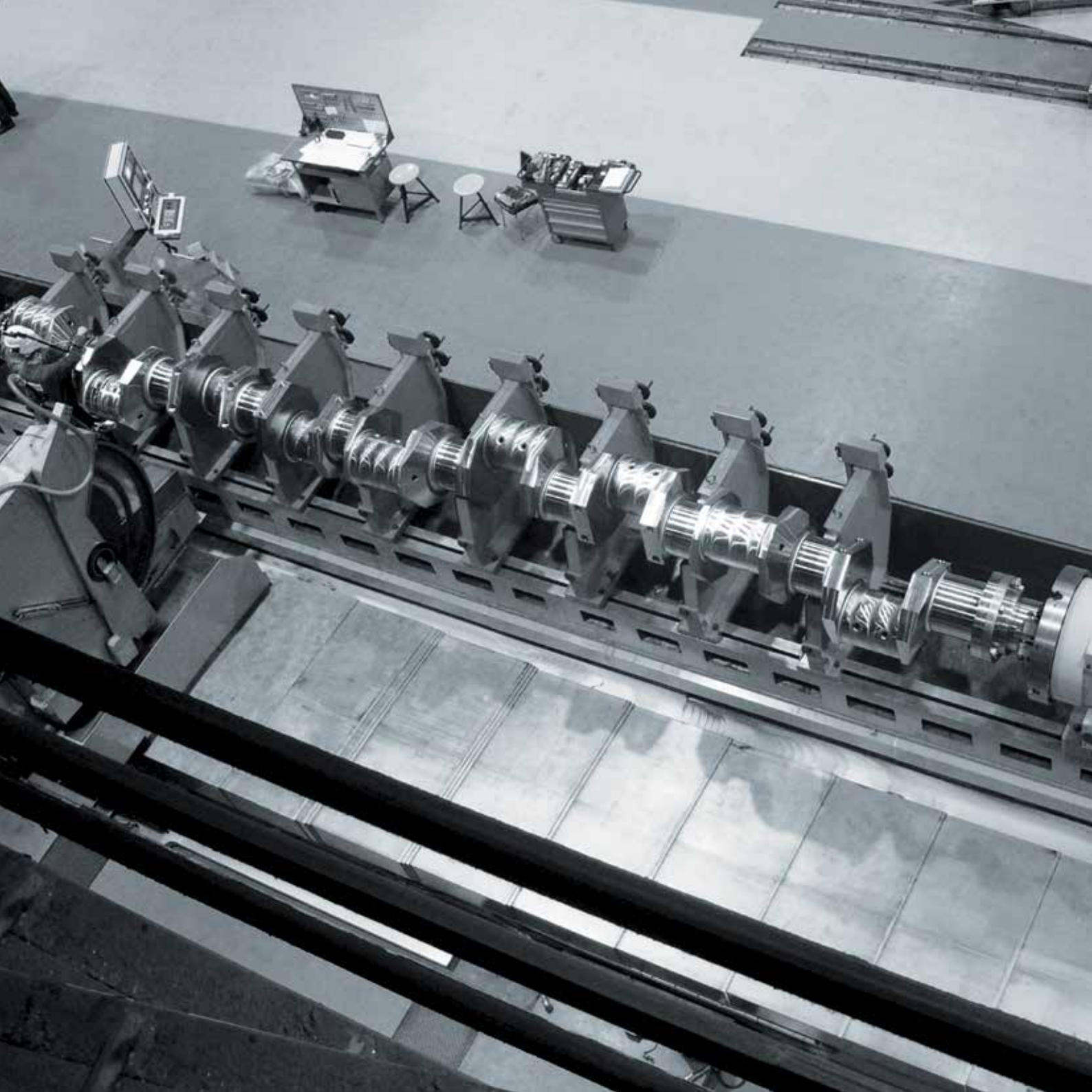

曲轴磨床



工件长度 WORKPIECE LENGTH  mm 	磨头移动 WHEELHEAD MOVEMENT		工作台移动 TABLE MOVEMENT		
					
	手动 MANUAL	随动 ORBITAL	随动 ORBITAL	液压 HYDRAULIC	CNC
600		<b>DU 600</b>			
800		<b>DU 800</b>			
1000		<b>DU 1000</b>			
1200		<b>DU 1200</b>			
1600	<b>CGA 270x1600</b>	<b>DU 800</b>			
2000	<b>CGA 270x2000</b>		<b>CGP 300</b>		<b>CGX 2000</b>
2200	<b>CGA 300x2200</b>				<b>CGX 3000</b>
3000			<b>CGP 400</b>		
3500	<b>CGA 360x3500</b>				
4000			<b>CGP 500</b>	<b>CG 600x4000</b>	<b>CG 600x4000</b>
4500		<b>DB 4500</b>		<b>CG 600x 5000</b>	<b>CG 600x5000</b>
5000					<b>CG 500</b>
5400				<b>CG 650x5400</b>	<b>CG 650x5400</b>
5500		<b>DB 5500</b>		<b>CG 600x5400</b>	
6000		<b>DB 6000</b>			
6400				<b>CG 650X6400</b>	<b>CG 650x6400</b>
8000		<b>DB 8000</b>			
10000		<b>DB 10000</b>			
12000		<b>DB 12000</b>			
14000		<b>DB 14000</b>			

■ 随动磨床  
Orbital machines.

■ 工作台移动式随动磨床  
Orbital machines with table  
movement.

■ 工作台液压移动式磨床  
Machines with hydraulic  
movement of the table.

## 最全范围

### The most complete range

#### 曲轴专家

AZ具有40年以上在曲轴磨床经验可以称为“曲轴专家”。3000曲轴磨床销往世界各地用于汽车，能源，海洋，机车，工程机械、石油和天然气。

**AZ CRANKSHAFT** AZ曲轴线是一个完整系列的曲轴磨床从1.5米到14米的曲轴长度。不同型号为满足不同的应用，从生产，售后和修理。根据客户需要，可以提供手动，PLC或数控机床。

#### CRANKSHAFT SPECIALISTS

More than 40 years of experience in crankshaft grinding machines permits AZ to be called the “crankshaft specialists”. 3000 crankshaft grinding machines sold all over the world for automotive, energy, marine, locomotive, earth moving and oil & gas applications.

**AZ CRANKSHAFT** line is a complete range of crankshaft grinding machines from 1.5 meter to 14 meters of crankshaft length. Different models for different application type first production, aftermarket and repair. Depend on technological level required, manual, PLC or CNC machines can be provided.

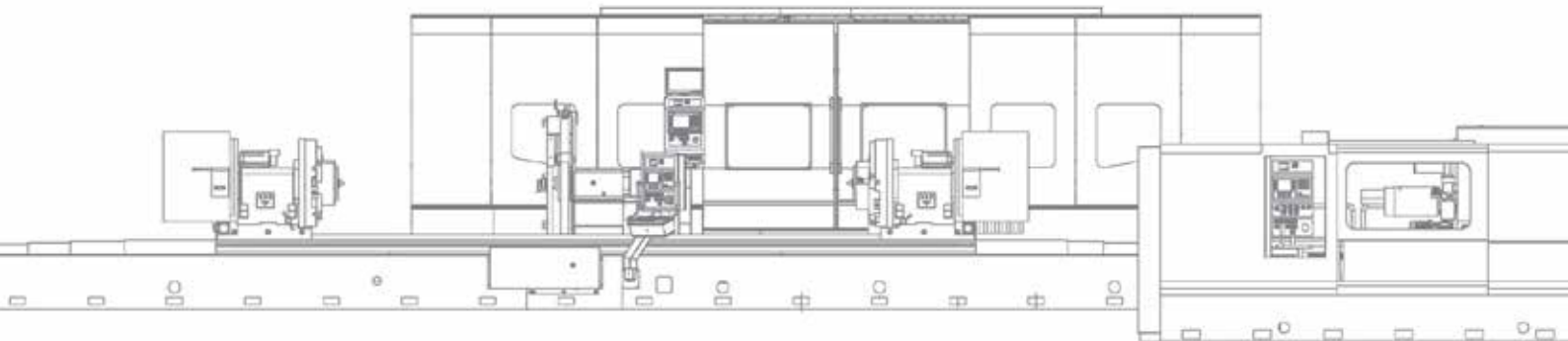



## 改造线

改造线是改造发动机一系列的曲轴磨床、曲轴从1,5米到14米。

**CG****CGX****CGA**

## REBUILDING line

The rebuilding line is a range of crankshaft grinding machines for the engine rebuilding, for crankshaft from 1,5 meters to 14 meters.

## 制造线

该生产线是一系列的数控磨床的设计、制造的高精度工程和大量生产。与数控系统的配置和使用市场最先进的技术设备 及最具创新性的测量系统。

**CGP****DB****DU**

## MANUFACTURING line

The manufacturing line is a range of grinding machines designed for high precision works and high volumes production. Machines with the most advanced technology used with CNC control system and equipped with the most innovative measurement systems on the market.

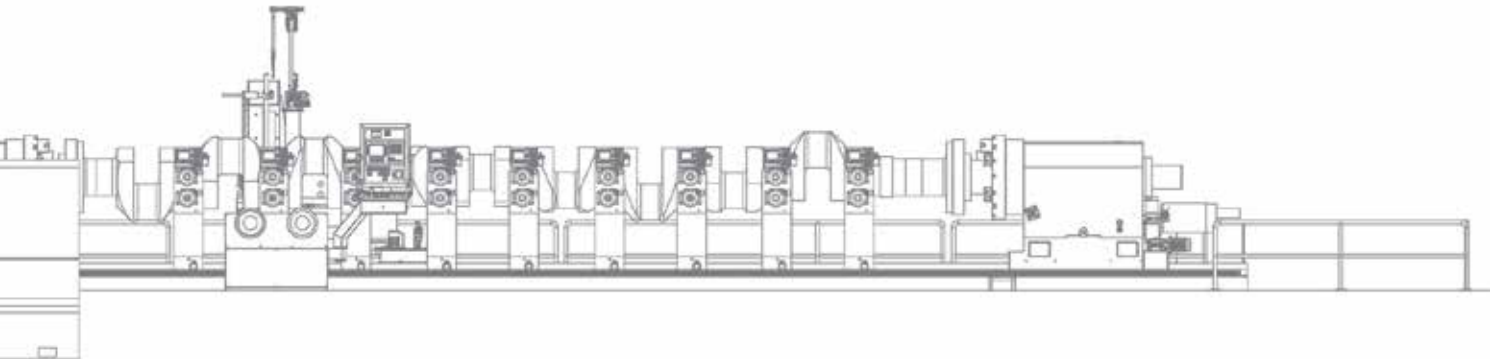

# 制造高质量 Manufacturing quality

## 床身

AZ曲轴磨床床身的制造工艺如下：

铸铁的热稳定结构与刮研接触面以具有经验的技能操作保证在不同位置最高的精度及平面度。



一种新的解决方案 **COMPOSITAL** 由树脂花岗岩  
沥青混合料填充焊接钢套管，许可证：

保持温度恒定  
减少机床的振动  
改善床身  
改善强度

## BED

The AZ crankshaft grinding machines beds are made of:

**CAST IRON** thermally stabilized strong structure with finishing by scraping the contact surface by skill operator in order to secure the highest precision and flatness in the different positions.

**COMPOSITAL**® a new solution composed by resine-granite mixture filled on welded-steel casing that permit to:

- Keep the temperature constant
- Reduce vibration on the machine
- Dumping improvement
- Strength improvement



## 工作头

该专业的设计与极端的精度都在交叉运动使一个简单而快速的调整，在轨道系统，我们发现完美的同步系统——离子角编码器。线性编码器的定位和重复性，确保与“闭环”系统。该工作头在气垫上移动。

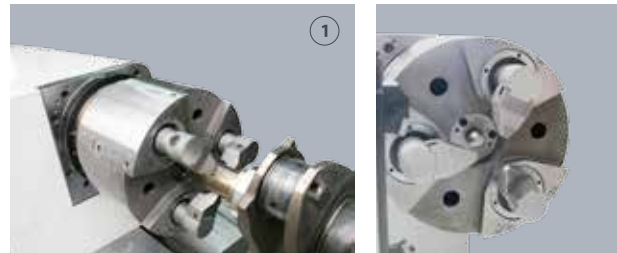

### 1 3爪自动夹紧液压工作头

Auto-clamping hydraulic workhead with 3 jaws chucks

### 2 重型4爪卡盘工作头

Heavy duty workhead 4 jaws chucks

## WORKHEADS

The workheads are designed with extreme precision both in the traditional system where cross movement ensures an easy and quick adjustment and in the orbital system where we find perfect synchronization with angular encoders. The positioning and repeatability are ensured by linear encoders with “closed loop” system. The workheads move on air cushion.

### 3 带十字滑块的3爪工作头

Workhead 3 jaws chucks with twin cross slide



## 磨头单元

### Grindinghead unit

在重型机型DB系列机床的磨头在X轴与静压导轨线性编码器控制下移动。在高生产率的曲轴磨床如DU系列机床磨头移动由X轴和Z轴的直线电机控制移动。

该磨头可以传统移动或随动移动。

In the heavy duty models like DB machines the grinding wheel head moves on X axis with hydrostatic guideways controlled by linear encoders. In high productivity crankshaft grinding machines like the DU machines the wheelhead moves on X and Z axes with linear motors. The grinding wheel head movements can be traditional or orbital.

### 随连杆颈随动

随动系统是指砂轮以曲柄销，工件旋转为中心线，不需要其他的设置。

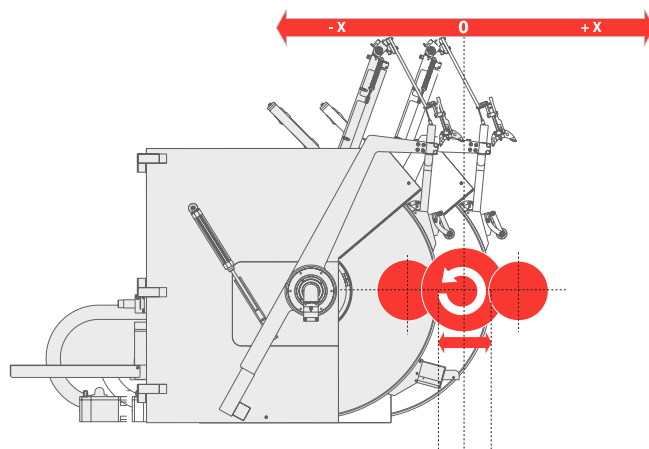

#### *"CHASE THE PIN" Orbital system*

The orbital system means that the grinding wheel chases the crankpin, the workpiece rotates on the centerline and is not necessary to have different setup.





## 砂轮

砂轮可以在任何类型的材料以不同的速度：33米/秒的硅、刚玉砂轮和120米/秒的CBN砂轮。



## GRINDING WHEEL

The grinding wheels allow to grind any type of materials at different speeds: 33 m/s for silicium and corundum grinding wheels and 120 m/s for CbN grinding wheels.



## 砂轮修整器

数控机床带有数控砂轮修整器，修正砂轮圆弧和砂轮侧面。

## WHEEL DRESSER

CNC machines have CNC wheel dresser with diamond roll for dressing the radius and sides of grinding wheels.



## 技术

### THE TECHNOLOGY

#### 先进的技术

AZ公司采用最先进的机电一体化解决方案。选择测量，控制系统等的全球领先供应商，和AZ工程师一起 进行创新生产的产品已出现在市场上。

#### THE MOST ADVANCED TECHNOLOGY

The machines producec by AZ perform the most advanced mechatronics solutions. The measurement, the movements, the controls are choosen on the top worldwide leader supplier and their combinations with AZ engineer creativity produce one of the most sofisticate range of products today on the market.

#### 机床可以配置不同的测量系统

- + 带有圆度控制功能的在线量仪
- + 形状控制系统
- + 测量不同位置的探针

The machine can be supplied with different measurement systems:

- + IN-PROCESS GAUGE WITH ROUNDNESS CONTROL FUNCTION
- + SHAPE CONTROL SYSTEM
- + PROBE FOR DIFFERENT POSITION MEASURING

CRANKSHAFTS GRINDING MACHINES

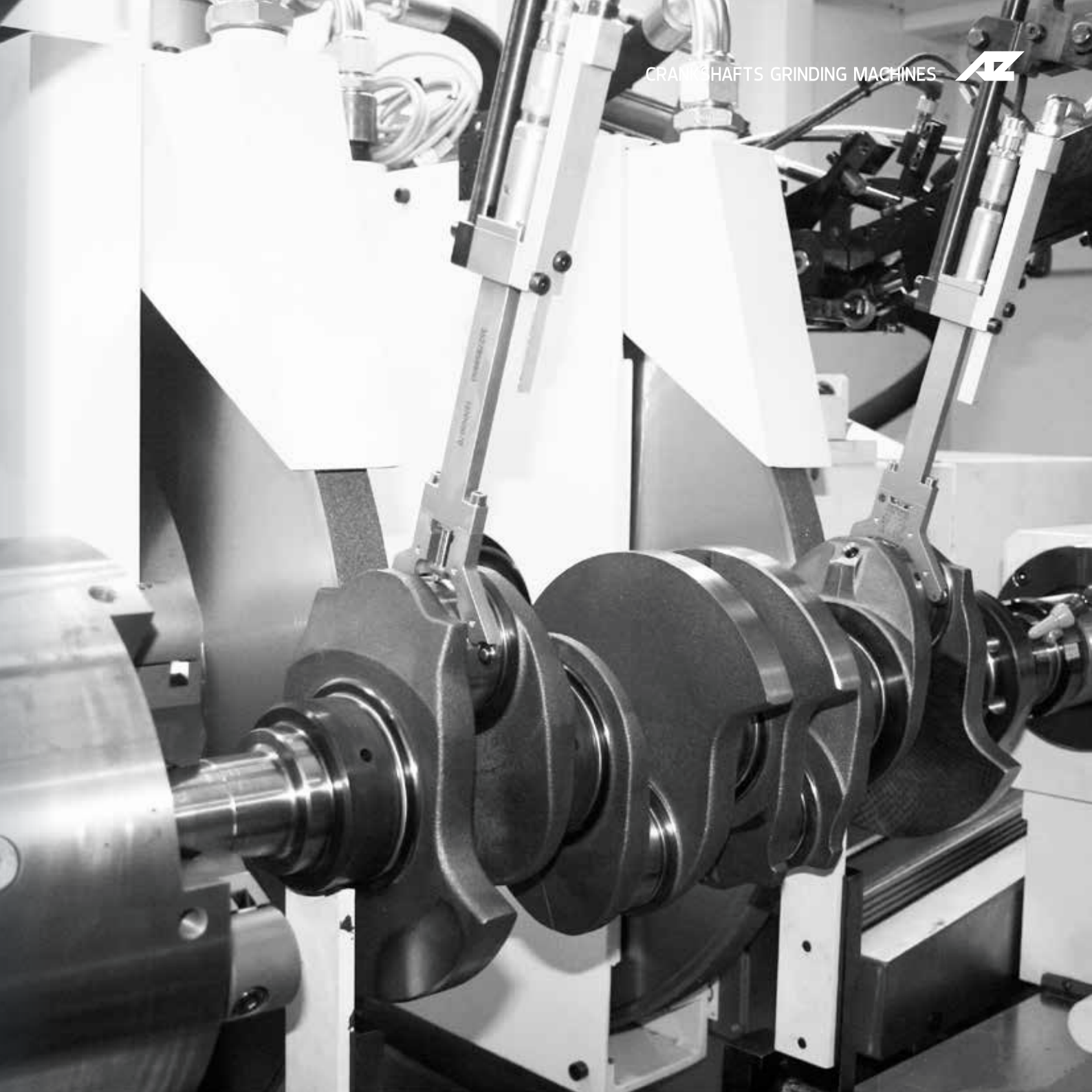

DB

## 重型曲轴磨床

CNC Heavy Duty Crankshafts Grinding Machines

AZ磨床可以加工14米长，25吨的曲轴

The queen of AZ production, for **crankshaft up to 14 meters** long and **25 Ton weigth**.

- + 随动系统  
Chase the pin
- + 同步工作头  
Synchronized workheads
- + 数控砂轮修整器  
CNC wheel dresser
- + 带有电子数显的中心架或带有自动定心的数控中心架。  
Steady rest with electronic digital readout or cnc steady rest with automatic centering



CRANKSHAFTS GRINDING MACHINES



CG

## 重型曲轴磨床

Heavy duty crankshaft grinding machines

CG系列机床采用传统机适用于维修曲轴重达6400毫米长。工作台上移动床与带有“V”形的具有摩擦处理的平板导轨罩。

The CG machines are traditional machines suitable for the **crankshafts rebuilding** up to 6400 mm long. The **table moves on bed** with “V” and flat guides cover with antifriction treatment.

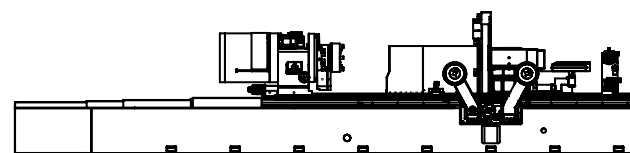
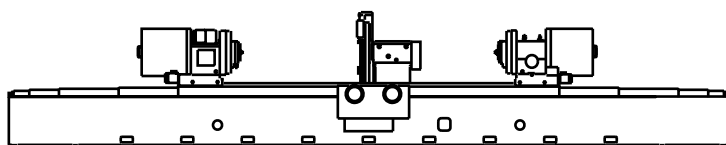

- + 工作头的机动化及同步化旋转  
Motorized and synchronized rotation of workheads
- + 手动、PLC 或数控系统  
Manual, PLC or CNC control
- + 保证曲轴定心精度的十字导轨  
Twin cross slide for precision crankshaft centering

- + 手动、液压或数控砂轮修整器  
Manual, hydraulic or CNC wheel dresser
- + 传统的砂轮  
Conventional grinding wheels

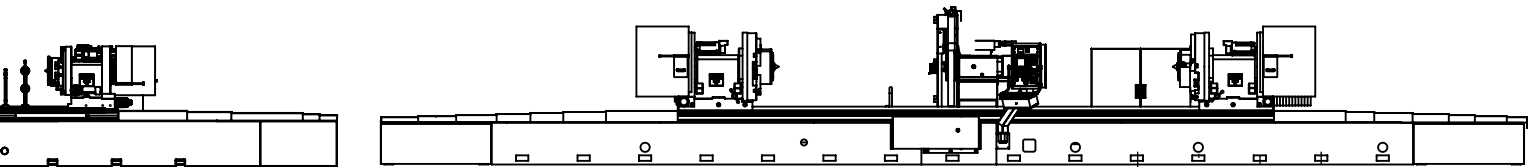

CGP

## 数控随动曲轴磨床

CNC Orbital crankshaft grinding machines

CGP系列是加工从1000到3500毫米长的曲轴。磨头的运动是随动的，并可配置的自动工作循环的“重复磨削”

The CGP series is for crankshafts from 1000 to 3500 mm long. The wheelhead movement is **orbital** and can be configured with **automatic working cycle** "ground to ground".

- + 工作头移动的随动系统  
Chase the pin system with table movement
- + 数控砂轮平衡系统  
CNC wheel balancing system

- + 传统的或CBN砂轮  
Conventional or CBN grinding wheel
- + 数控砂轮修整器  
CNC wheel dresser







回转直径 510-610 mm  
SWING

工件长度 600-1600 mm  
WORKPIECE LENGTH

DU

## 用于高生产率的数控曲轴磨床

CNC Crankshaft grinding machines for high productivity

高生产率汽车工业用机床。令人难以置信的节拍和精度，最新的夹紧和测量技术。本机带有两个独立砂轮架随动，同时这是高生产率的最佳解决方案。

Machine for the **automotive** industry for high productivity. Unbelievable cycle time and precision, the most update technology for clamping and measuring. The machine can have **two independent grinding wheel carriages** that move simultaneously this is the best solution for high productivity.

- + 床身由复合材料制成  
Base made of composital
- + 随动系统  
Chase the pin system
- + 数控砂轮修整器  
CNC Wheel dresser

- + 数控砂轮平衡器  
CNC Wheel balancing system
- + 带有双量仪的在线直径测量系统  
In-process diameter measuring system with double fork

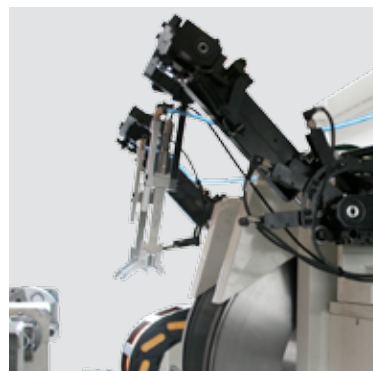

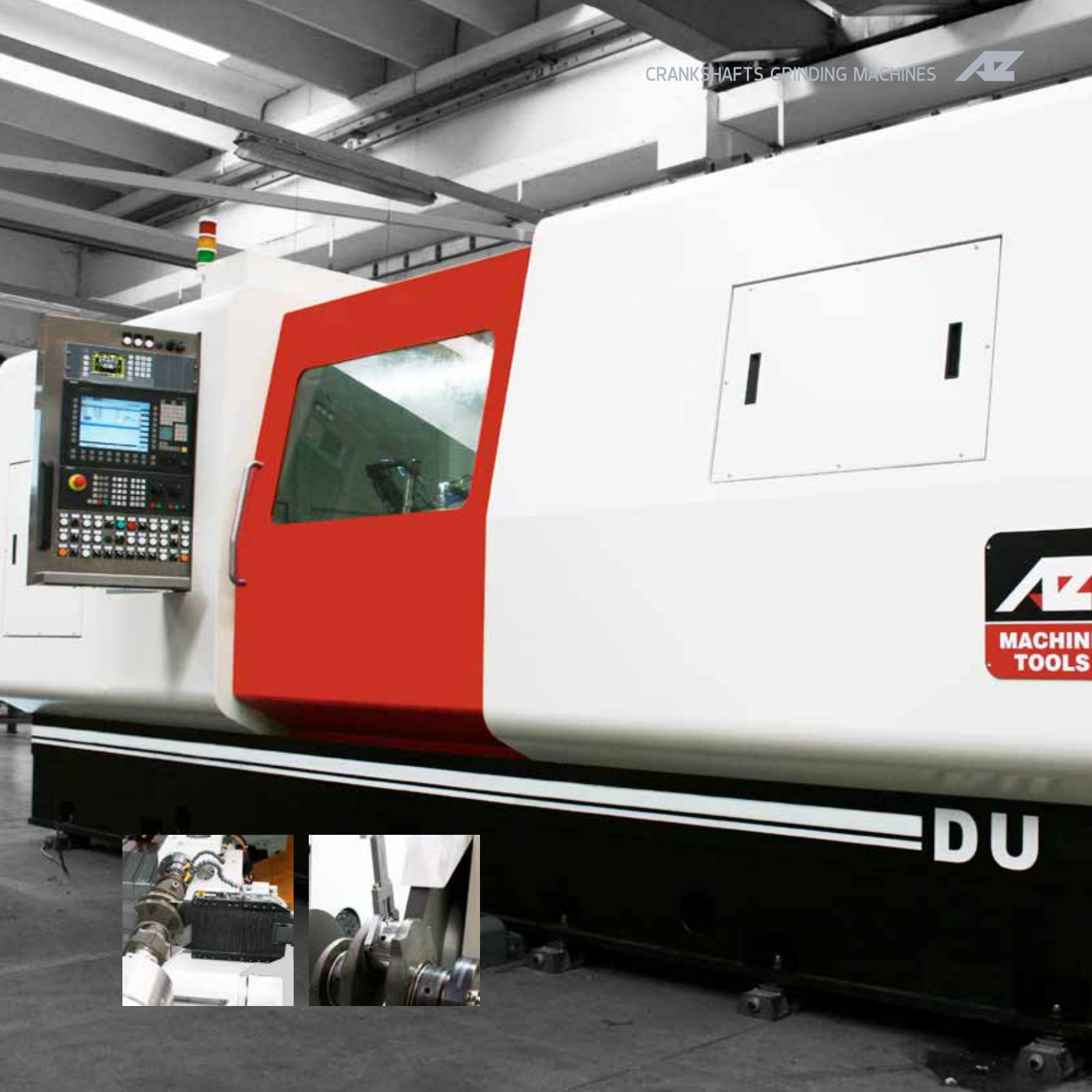

回转直径  
SWING 540-720 mm

工件长度  
WORKPIECE LENGTH 1600-3500 mm

CGA CGX 小型曲轴磨床  
Crankshaft grinding machines

CGA和CGX机型可手动或数控。手动模式适用于长度为1600mm以内的曲轴。所有的机床型号带有整体防护与滑动门的专用窗口并可调整中心架，具有双十字滑块的高精度曲轴定心。

The CGA and CGX machines can be manual or CNC. Manual version suitable for crankshaft till 1600 mm. All machines models have integral guarding with sliding doors with **special window to permit the adjustment of steady rest**. Machines with twin cross slide for precision crankshaft centering.

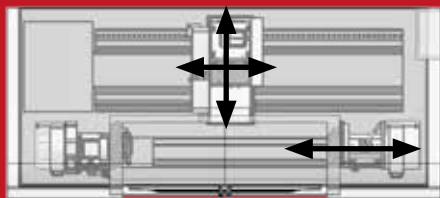



- + 机动化及同步化的工作头  
Motorized and synchronized rotation of workheads
- + 手动、PLC或数控  
Manual, PLC or CNC control
- + 高精度曲轴定心的双十字滑块  
Twin cross slide for precision crankshaft centering
- + 手动、液压或数控砂轮修整器  
Manual, hydraulic or cnc wheel dresser
- + 传统砂轮  
Conventional grinding wheels

- ① 手动中心架  
Manual steady rest
- ② 数控砂轮修整器  
CNC wheel dresser
- ③ 砂轮表面、侧面及圆弧修整器  
Wheel face, side and radius dresser





# 欧洲制造 意大利制造

AZ spa  
via dell'elettronica 20  
36016 Thiene (VI) ITALY

T +39 0445 575543  
F +39 0445 575756  
*info@azspa.it*





Marketing Dept. of AZ spa EN/IT - 20170213

版权©AZ 2017本文档，在没有AZ公司书面许可下，任何部分不得转载，复制，改编，或以任何形式或任何方式没有明确的书面许可从AZ SPA信息给出了BAS。这本小册子印刷时，随着我们的机器技术水平的提高，我们会对名称，设计，技术规格、设备等会有相应的变更。

AZ Copyright © 2017 No part of this document may be reproduced, copied, adapted, or transmitted in any form or by any means without express written permission from AZ spa. The informations given is based on the technical levels of our machine at the time of this brochure going to print. We reserve the right to further develop our machines technically and make name, design, technical specifications, equipment etc. modifications.



AZ spa  
via dell'elettronica 20  
36016 Thiene (VI) ITALY

T +39 0445 575543  
F +39 0445 575756  
*info@azspa.it*